

Xia[®] 3 Spinal System

Surgical Technique



Introduction

Built on the successful foundation of Xia's history, Stryker Spine is proud to introduce Xia 3; a pedicle screw system designed to deliver **"Simplicity with Options."**

Xia 3 is a comprehensive system that is designed to treat modern deformity, degenerative, and trauma applications. Xia 3 is based upon the same design rationale and philosophy that has made Xia one of the leading spinal systems in the market.

- Ease of Use
- Comprehensive System
- Proven Core Technology
- Successful Clinical History

Acknowledgements

Stryker Spine would like to extend their thanks to the following surgeons for their dedication and contributions:

- Tushar Patel, MD
- Alex Vaccaro, MD

Table of Contents

Surgical Technique

Key Design Features	4
Patient Positioning	5
Preparing the Pedicle	6
Screw Insertion	10
Rod Contouring	16
Rod Linkage	19
Final Tightening	28
Cross Connectors	29
Uniplanar Screws	30
Reduction Procedures	31
Hooks	32
<hr/>	
Implants	35
Instruments	40
Indications and Contraindications	43
General Condition of Use	44

Key Design Features

Xia 3 Polyaxial Screw

- **Xia Buttress Thread Blocker**

With almost a decade of consistent performance, the Xia buttress thread blocker helps to eliminate cross-threading, prevent screw head splaying, and helps ensure secure closure.

- **Xia Bone Screw Thread Pattern**

Based on patient anatomy, the Xia bone screw thread pattern is designed to increase performance and purchase in cortical and cancellous vertebral bone.

- **Self-Tapping Screws**

Aggressive cutting flute is designed to provide surgeons the option of eliminating the tapping step of the surgical procedure.

- **Rod Options**

Xia 3 screws can accommodate a variety of rod diameters and materials; 5.5mm and 6.0mm diameter rods in Commercially Pure Titanium, Titanium Alloy, and Vitallium.

- **Screw to Screwdriver Interface**

Intimate 6-point star engagement between the screwdriver and screws is designed to decrease toggle, intuitively align when loading, and re-engage for screw adjustments.

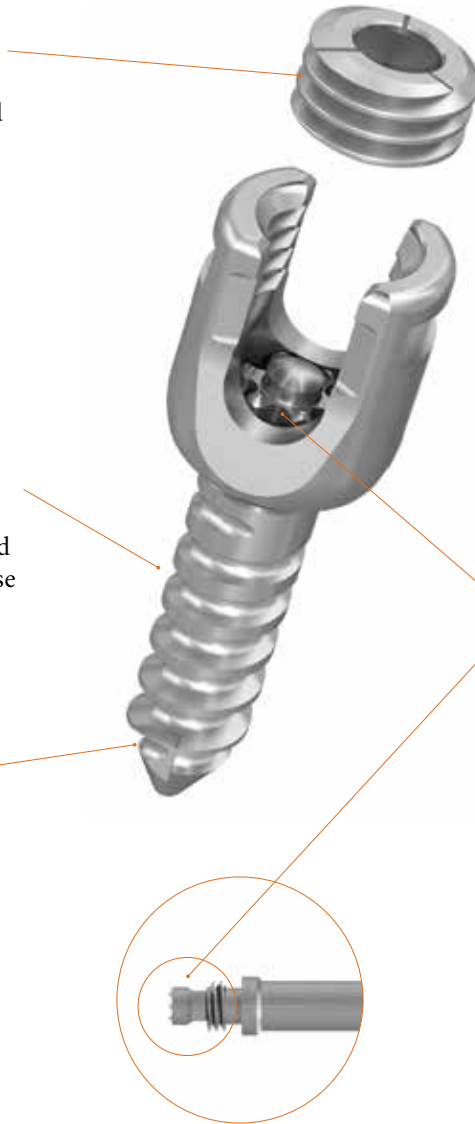

Xia 3 Screwdriver



- **Technology Driven Instruments**

With an engineering commitment to innovation, Xia 3 instruments have introduced technologies to help improve function and efficiency in the OR.

- **Ergonomic Handles**

Stryker branded handles are designed to enhance comfort, function, and efficiency.

Patient Positioning

Diagnosis is based upon patient history, physical findings, and preoperative radiographic assessment.



The patient can be positioned on the operating table in the prone position. Care should be taken to pad all bony prominences. To facilitate venous drainage, the abdomen should not be compressed.



Surgical levels may be verified either clinically or radiographically. To help ensure adequate exposure, the incision is made to extend just beyond the length of the intended fusion.

Presurgical planning defines the most appropriate implants in addition to the optimal location for insertion of implants.

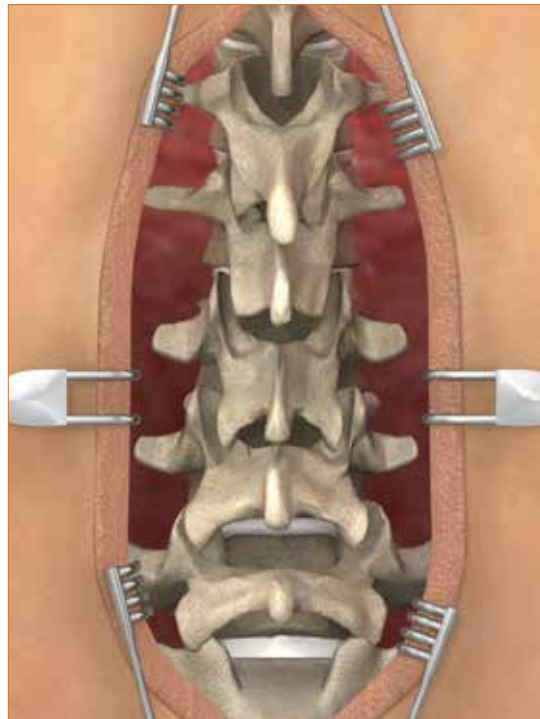

Preparing the Pedicle



Awl 48237111

Once anatomical landmarks are identified, remove the cortical crest with a rongeur or power burr to expose the underlying cancellous bone.

Prepare the entry point with the **Awl**. The Awl is designed with a stop at 13mm to prevent overplunging.

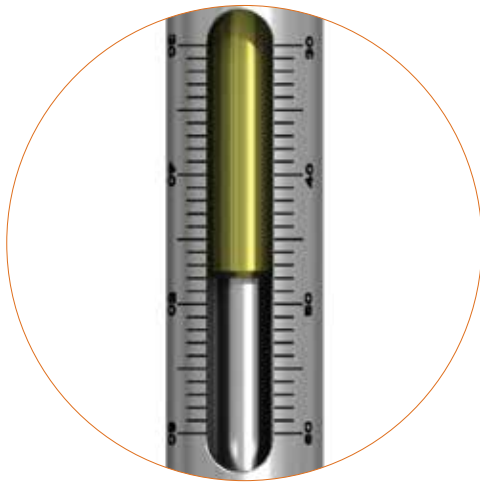

Sacral Awl 482397002

When placing sacral screws, the **Sacral Awl** can be used. Set the depth indicator on the Sacral Awl to the desired length; the sacral awl depth indicator can be set from 30mm to 60mm. The stop on the Sacral Awl is designed to prevent overplunging while breaching the anterior cortex.

NOTE: The Sacral Awl must only be used for 6.5mm diameter screws and larger.

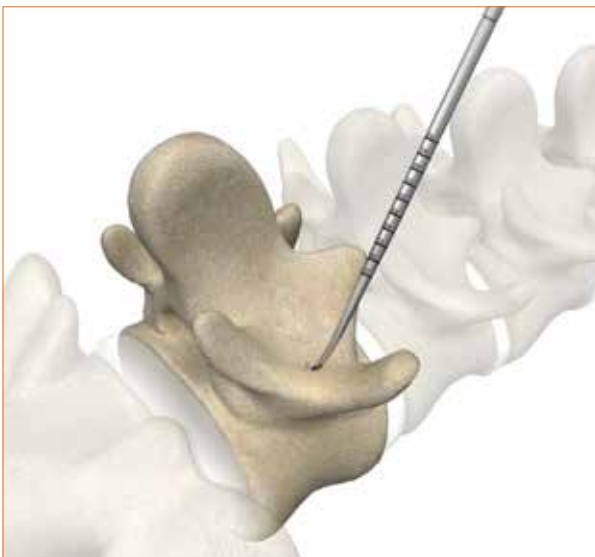

Using the **Curved Blunt Probe**, the **Thoracic Pedicle Probe**, or the **Adjustable Curette Probe**, create a pathway into the pedicle. The correct rotational insertion of the instrument allows the probe to follow a path of least resistance without violating the pedicle walls. In the case that resistance is met, the entry point and trajectory should be reevaluated.

Preparing the Pedicle

There are three probe options available with Xia 3. The primary differentiating feature of the Curved Blunt Probe, the Thoracic Pedicle Probe, and the Adjustable Curette Probe is the tip. The Curved Blunt Probe has a flat tip. The Thoracic Pedicle Probe has a sharp, pointy tip designed to optimize its use in the thoracic region of the spine. The Adjustable Curette Probe has a curette tip as another blunt tip option.

The Curved Blunt Probe and the Thoracic Pedicle Probe are laser marked in 5mm intervals to help indicate the depth in which the probe has been inserted. The Adjustable Curette Probe has an adjustable depth stop which allows the probe to be inserted to the indicated depth; the depth indicator can be set from 35mm to 50mm. These depth indicators on the probes are also helpful in determining the appropriate screw length.

NOTE: The Curved Blunt Probe and the Adjustable Curette Probe must not be used to prepare holes for 4.0mm diameter screws. The Thoracic Pedicle Probe is recommended for 4.0mm diameter screws.

Follow the prepared pathway with the **Pedicle Feeler** to confirm the walls of the pedicle have not been violated. Pedicle Feelers are available in **Malleable, Medium, and Stiff**. Pedicle Feelers are laser marked in 10mm intervals. A **Double Ended Pedicle Feeler** is also available to feel the pedicle walls for any breaches.

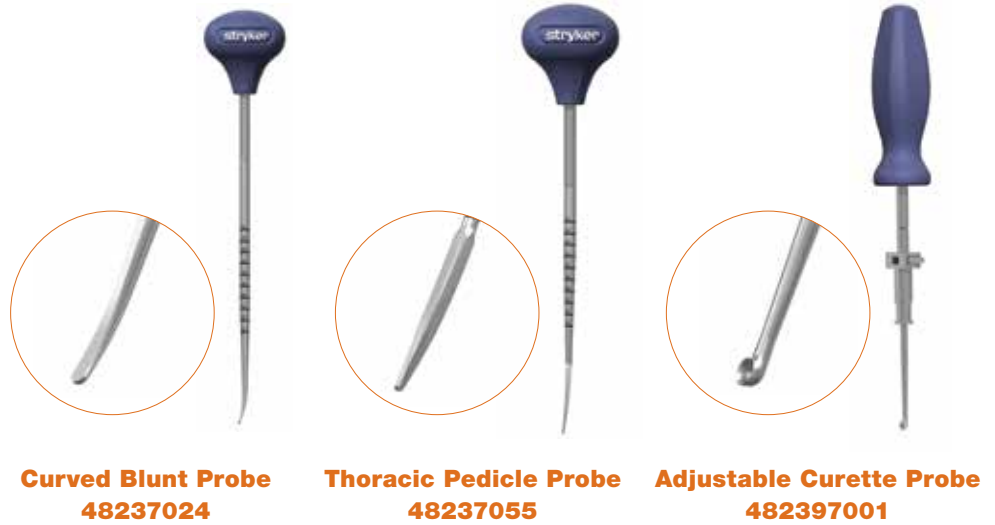

Curved Blunt Probe
48237024

Thoracic Pedicle Probe
48237055

Adjustable Curette Probe
482397001



Pedicle Feeler - Malleable
48237060

Pedicle Feeler - Medium
48237059

Pedicle Feeler - Stiff
48237003

Double Ended Pedicle Feeler
48237061

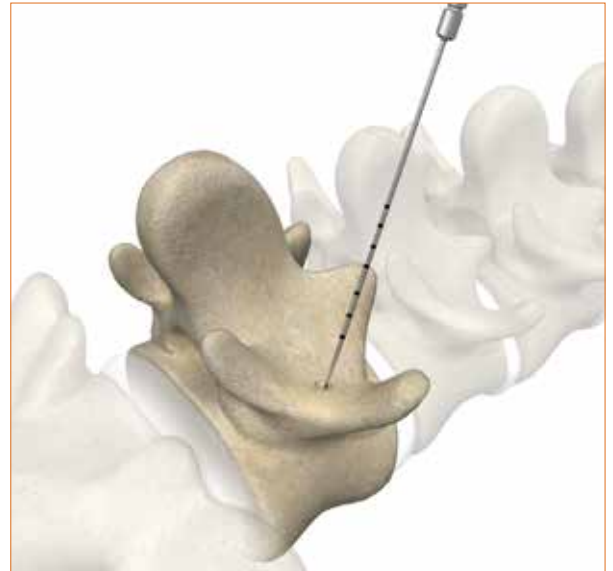

Preparing the Pedicle



Ø3.0mm Modular Tap	48230030
Ø3.5mm Modular Tap	48230035
Ø4.0mm Modular Tap	48230040
Ø4.5mm Modular Tap	48230045
Ø5.0mm Modular Tap	48230050
Ø5.5mm Modular Tap	48230055
Ø6.5mm Modular Tap	48230065
Ø7.5mm Modular Tap	48230075
Ø8.5mm Modular Tap	48230085
Ø9.5mm Modular Tap	48230095
Ø10.5mm Modular Tap	48230105



For increased bone purchase, use the **Modular Taps** to prepare the pedicle canal. After attaching a Xia 3 handle, insert the Modular Tap into the pedicle and into the vertebral body. The Modular Taps are laser marked with lines in 5mm increments and numbers in 10mm increments.

Taps are available in the following sizes:

- Ø3.0mm Modular Tap
- Ø3.5mm Modular Tap
- Ø4.0mm Modular Tap
- Ø4.5mm Modular Tap
- Ø5.0mm Modular Tap
- Ø5.5mm Modular Tap
- Ø6.5mm Modular Tap
- Ø7.5mm Modular Tap
- Ø8.5mm Modular Tap
- Ø9.5mm Modular Tap
- Ø10.5mm Modular Tap

NOTE: The nomenclature describing the taps represents the actual tap line to line diameter. This is different from previous versions of the Xia System.



Preparing the Pedicle

The Modular Taps can be attached to any one of the following Xia 3 Handles:

- T-Handle
- T-Handle, Ratchet
- Round Handle
- Round Handle, Ratchet
- Small Round Handle
- Small Round Handle, Ratchet



T-Handle
48231201



T-Handle, Ratchet
48231202



Round Handle
48231301



**Round Handle,
Ratchet**
48231302



Small Round Handle
482397006



**Small Round
Handle, Ratchet**
482397005

NOTE: The **Jacobs Chuck Handle** is another handle option for the Xia 3 system. This handle can be hand tightened or the chuck key can be used to secure the handle. Ensure proper engagement between the handle teeth and the instrument shaft surface.



Jacobs Chuck Handle
482397007

Screw Insertion



The Xia 3 Monoaxial and Polyaxial Titanium Self-Tapping Screws have a cutting flute to allow a surgeon to eliminate the tapping step. The screws may be inserted immediately after preparing and probing the pedicle. However, in most cases, tapping is recommended.

Titanium screws are fully anodized by screw diameter for easier identification in the OR.

Xia 3 thread pattern is designed for optimal performance and purchase in cortical and cancellous vertebral bone.



The 6-point star screw head is designed:

- For faster and more intuitive engagement with the screwdriver
- To prevent screw head stripping
- For reengagement during screw adjustments

Xia 3 Titanium Polyaxial and Monoaxial Self-Tapping Screws:



Diameter	4.0mm	4.5mm	5.0mm	5.5mm	6.0mm	6.5mm	7.0mm	7.5mm	8.5mm	9.5mm	10.5mm
Length	20mm-45mm	20mm-45mm	20mm-50mm	25mm-55mm	25mm-90mm	25mm-90mm	25mm-90mm	25mm-90mm	25mm-100mm	40mm-100mm	40mm-100mm

Screw Insertion

With the pedicle pathway prepared, and the proper screw diameter and length determined, the screw can be inserted into the pedicle using the appropriate Xia 3 Screwdriver.

The **Polyaxial Screwdriver** and **Monoaxial Screwdriver** provide a more rigid connection between the screw and the screwdriver.

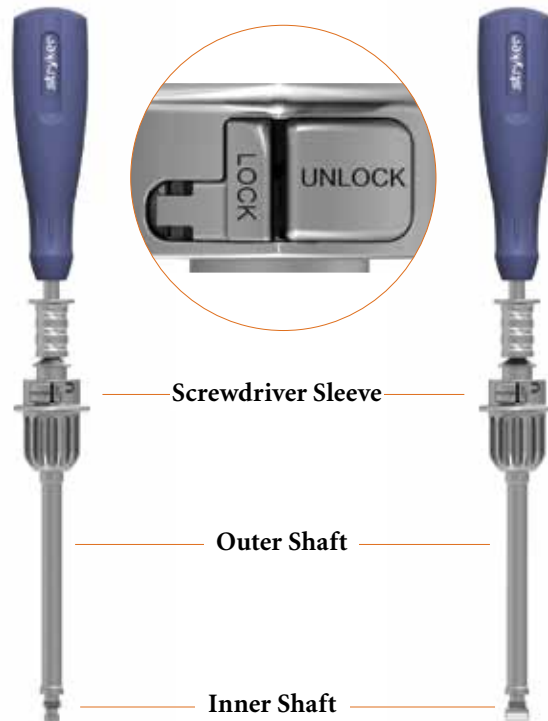

The Polyaxial and Monoaxial Screwdrivers come in three different sizes.

- Short Polyaxial Screwdriver
- Standard Polyaxial Screwdriver
- Long Polyaxial Screwdriver
- Short Monoaxial Screwdriver
- Standard Monoaxial Screwdriver
- Long Monoaxial Screwdriver

The Polyaxial and Monoaxial Screwdrivers can be connected to any of the Xia 3 handles.

A primary design goal of the Xia 3 system is to help improve the connection between the screw and the screwdriver. The Polyaxial and Monoaxial Screwdrivers were designed to help decrease toggle at two integral points of connection:

- Screwdriver to screw interface
- Screwdriver to shaft interface

The Screwdriver locking feature is designed to provide tactile, visual, and audible confirmation that the screwdriver is more securely locked.

Xia 3 Polyaxial Screwdriver
Standard 48231330
Short 482391330S
Long 48231330L

Xia 3 Monoaxial Screwdriver
Standard 48231320
Short 482391320S
Long 482391320L



Screwdriver Length Options

Screw Insertion



To assemble and engage the Xia 3 Polyaxial and Monoaxial Screwdrivers:

STEP 1:

Press the “UNLOCK” button on the Outer Shaft.



STEP 2:

Insert the **Polyaxial** or **Monoaxial Inner Shaft** down the Outer Shaft.



STEP 3:

Slide the **Screwdriver Sleeve** up the Inner Shaft. Verify the Sleeve for Screwdriver is completely bottomed out.

Screwdriver Sleeve 48231330S



STEP 4:

Align the tabs and fully insert the quick connect mechanism into the shaft.

Screw Insertion

STEP 5:

Hold the screw by the threads and engage the tabs on the Screwdriver Inner Shaft into the saddle of the screw head.

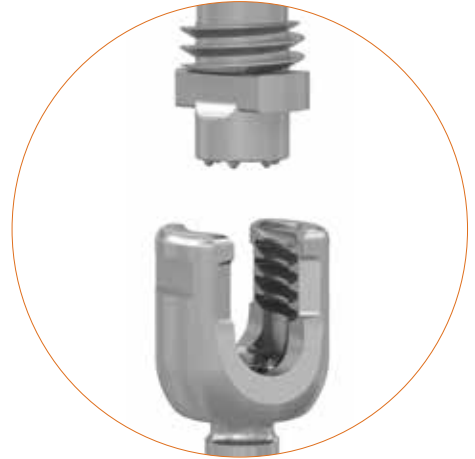

STEP 6:

Fully seat the Inner Shaft into the screw head. Turn the Outer Shaft clockwise using the "LOCK" button until the threads are fully engaged.

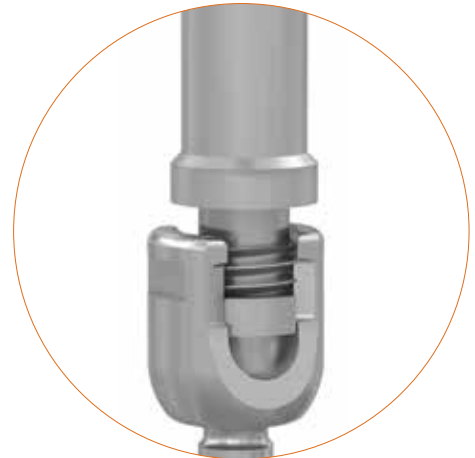

STEP 7 (Optional):

If the ratchet sound is not present, confirm locking by pressing the "LOCK" button.



Screw Insertion



To disengage and disassemble the Xia 3 Polyaxial and Monoaxial Screwdrivers:

Once the screw is placed, to disengage the Screwdriver press and release the “UNLOCK” button. Rotate the Outer Shaft counterclockwise while firmly holding the handle.

Release the quick connect handle from the Sleeve and Inner Shaft. Remove the Sleeve by sliding it down the Inner Shaft. Remove the Inner Shaft from the Outer Shaft.

NOTE: The Xia 3 Low Profile Screwdriver provides an alternative locking mechanism to the standard Xia 3 Screwdriver while maintaining the 6-point star screw to screwdriver interface.

Screw Insertion

To assemble and engage the Xia 3 Low Profile Screwdriver:

- STEP 1:** Insert the Polyaxial Inner Shaft down the Outer Shaft.
- STEP 2:** Slide the Locking Nut over the Inner Shaft with the serrated teeth positioned distally.
- STEP 3:** Slide the Screwdriver Shaft Adapter over the Inner Shaft.
- STEP 4:** Align the tabs and fully insert the handle quick connect mechanism onto the Screwdriver Shaft Adapter.
- STEP 5:** Hold the screw by the threads and engage the tabs on the Inner Shaft into the saddle of the screw head.
- STEP 6:** Fully seat the Inner Shaft into the screw head. Turn the Outer Shaft clockwise until the threads are fully engaged.
- STEP 7:** Depress the button on the Locking Nut and slide the Locking Nut into the Outer Shaft to lock the screw to the screwdriver.



- Screwdriver Shaft Adapter
- Locking Nut
- Outer Shaft
- Inner Shaft

**Xia 3 Low Profile
Screwdriver
482397004**

To disengage and disassemble the Xia 3 Low Profile Screwdriver:

Unlock the Screwdriver from the screw by depressing the Locking Nut button and sliding it up out of the Outer Shaft.

While pulling upward, turn the Outer Shaft counterclockwise to disengage the threads from the screw head.

Release the quick connect handle from the Screwdriver Adapter and Inner Shaft.

Remove the Screwdriver Adapter and Locking Nut by sliding them off the Inner Shaft.

Remove the Inner Shaft from the Outer Shaft.

Rod Contouring



Laser markings serve as a point of reference for bending the rod

Male hex end is often used for derotation

The Xia 3 screws are designed to accommodate 5.5mm and 6.0mm diameter rods. This versatility is designed to present various size and stiffness options to meet a spectrum of surgical needs. Pre-bent Rad Rods and Max Rad Rods are also compatible with this system.

NOTE: Straight rods 90mm and greater have hex ends.



Once all the screws are inserted, the appropriate length rod is determined. Use the **Rod Template** to more accurately determine the appropriate rod length.

Rod Template 03710620



Table-Top Rod Cutter 48238400 and Stand 48238400S

Use the appropriate pre-cut rods or cut a longer rod to the desired length using the **Table-Top Rod Cutter** and **Stand**.



French Benders 48237010



Tube Benders 48230191L 48230191R



To fit the desired spinal contours, rod bending is performed. Bending can be performed with the **French Benders** or the **Tube Benders**. To contour the rod, a series of small incremental adjustments will bend the rod gradually and help ensure even stress distribution on the rod.

NOTE: Do not repeatedly contour the rod. Care should be taken to not make extreme bends, so as to avoid stress concentration and notching of the rod. Do not contour a bent rod in the opposite direction; bending and unbending the rod.

Rod Contouring

Once the rod is bent to the desired contour, the **Rod Insertion Forceps** or **Rod Gripper** can be used to help place the rod into the grooves of the implant.

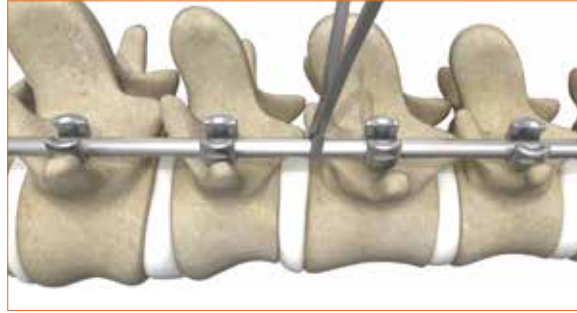

Rod Insertion Forceps
48230140



Rod Gripper
48231140

The **In Situ Rod Benders** and the **Coronal Plane Benders** can be used to achieve final incremental correction maneuvers. Care should be taken to not make extreme bends as that can cause stress concentration and notching of the rod.



In Situ Rod Benders
48237011L, 48237011R



Coronal Plane Benders
48230180, 48230190



Ball Joint
48230180S

Rod Contouring



Blocker
48230000

The Xia 3 Spinal System uses the Xia Buttress Thread Blocker as its closure mechanism. The titanium blocker is laser etched to more clearly differentiate it from other materials. The blocker is assembled onto the **Universal Tightener** for insertion. The Universal Tightener is available in three different options; standard, short, and double-ended.

NOTE: The Xia 3 Universal Tightener is not to be used for final tightening.



Universal Tightener
48237008



Short Universal Tightener
482397008



Double-Ended Universal Tightener
48237065

Rod Linkage

Xia 3 offers seven options for linking the rod to the spine:

Option 1: Inserter Tube and Universal Tightener

The Inserter Tube helps align the Universal Tightener and the blocker with the implant.



**Inserter Tube
48237109**

**Short Inserter Tube
482397109**

The two engraved lines on the Universal Tightener denote the following:

- When the *lower* line is aligned with the top of the Inserter Tube, the blocker is at the top of the implant.



- When the *upper* line is aligned with the top of the Inserter Tube, the blocker is fully introduced into the implant.



NOTE: The lower and upper indication lines reflect the above described positions of the blocker in relation to the implant when the Standard Universal Tightener is used with the Standard Inserter Tube, and when the Short Universal Tightener is used with the Short Inserter Tube. The Standard Universal Tightener can be used with the Short Inserter Tube, but the lower and upper indication lines will not denote the position of the blocker with respect to the implant. Do not use the Short Universal Tightener with the Standard Inserter Tube.

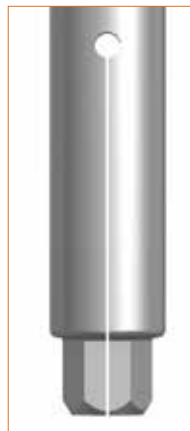

Split hex design for secure engagement to blocker

NOTE: The Xia 3 Universal Tightener is not to be used for final tightening.



Rod Linkage

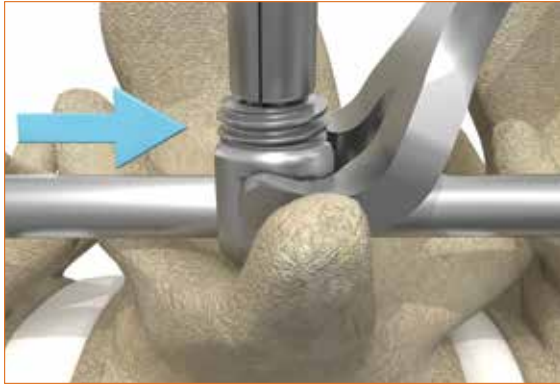

**Rod Fork
48237018**

Option 2: Rod Fork and Universal Tightener

When the rod is slightly proud with respect to the seat of the implant, the **Rod Fork** can be used.

Slide the Rod Fork into the lateral grooves on the implant head and rotate backwards. This motion levers the rod into the head of the implant. When the rod is fully seated into the head of the implant, insert the blocker with the Universal Tightener.

NOTE: The Xia 3 Universal Tightener is not to be used for final tightening.

Option 3: Persuader

Use the **Persuader** when additional force is needed to bring the rod to the implant. The Persuader is available in two sizes; standard and short.

The Persuader has two windows at the top and two windows at the bottom of the instrument for visibility.

The **Hex Drive T-Handle** can be attached to the Persuader for additional leverage.

There are three key indication lines on the Persuader:



**Persuader 48237016
Short Persuader 482397016**



**Hex Drive T-Handle
48237017**

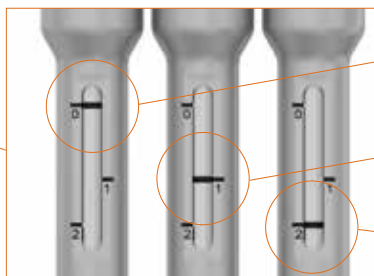

- At "0", the Persuader can be connected to the implant.
- At "1", the Persuader is locked to the implant.
- At "2", the rod is fully seated.

Rod Linkage

Verify the indication line on the Persuader is in the “0” starting position.

Connect the Persuader to the head of the implant. Rotate the handle of the Persuader clockwise until the indication line is in the “1” position. At this position the Persuader is locked to the implant and the rod can be pushed into the screw.



Rotate the handle of the Persuader clockwise until the indication line is in the “2” position. At this position, the rod is fully seated and the blocker can be inserted using the Universal Tightener.



To remove the Persuader, rotate the handle counterclockwise until the indication line is in the “0” starting position and twist the instrument to disengage from the implant.

NOTE: Blockers can be inserted through the Persuader into the screw heads. The Short Universal Tightener will not work with the Standard Persuader.

NOTE: The Xia 3 Universal Tightener is not to be used for final tightening.

Rod Linkage



Option 4: One Handed Persuader

The **One Handed Persuader** is designed to quickly and easily bring the rod to the implant.

Connect the One Handed Persuader to the head of the implant with the handle in the open position.

Squeeze the handle until it reaches the shaft of the instrument. As the handle is depressed, the rod is brought to the implant.

Designed with a natural stop, the One Handed Persuader provides tactile feedback and helps prevent over persuasion. In addition, the ratchet sound provides audible feedback to confirm the rod is fully seated. At this point, the blocker can be inserted with the Universal Tightener.

To remove the One Handed Persuader, slide the lock release and twist the instrument to disengage from the screw.

NOTE: Blockers can be inserted through the One Handed Persuader into the screw heads. The Short Universal Tightener will not work with the One Handed Persuader.

NOTE: The Xia 3 Universal Tightener is not to be used for final tightening.

In the event the rod is forced down while tightening the blocker, be sure that the blocker is fully engaged into the screw head. This will help resist the high reactive forces generated by the final tightening maneuvers.

CAUTION: Extra caution is advised in the following cases:

- The rod is not horizontally placed into the screw head.
- The rod is high in the screw head.
- An acute convex or concave bend is contoured into the rod.

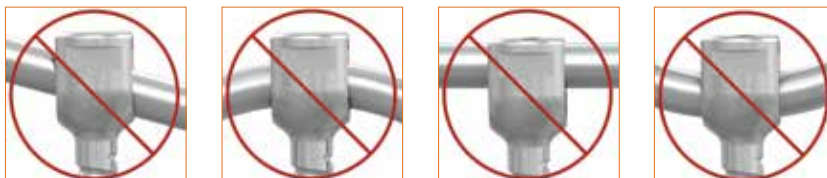

Rod Linkage

Option 5: Lateral Persuader

The **Lateral Persuader** is designed to aid in medializing and reducing the rod when it is not centered over the tulip.

Before use, ensure that the center tube is unthreaded to its desired height.

Connect one of the distal ends of the Lateral Persuader to the head of the implant with the handle in the open position. Squeeze the handle until the rod is medialized over the tulip. Rotate the center tube clockwise until the rod is fully seated in the tulip head. A physical stop will indicate when the rod is in position.

If additional torque is needed to persuade the rod, a T-Handle (48237097) from the SUK DVR System can be connected to the proximal end of the tube for added leverage.

NOTE: For instrument cleaning, unthread the center tube fully from the Lateral Persuader and clean the pieces separately.

NOTE: Blockers can be inserted through the Lateral Persuader into the screw heads with the Xia 3 Universal Tightener. The Short Universal Tightener will not work with the Lateral Persuader.

NOTE: The Xia 3 Universal Tightener is not to be used for final tightening.

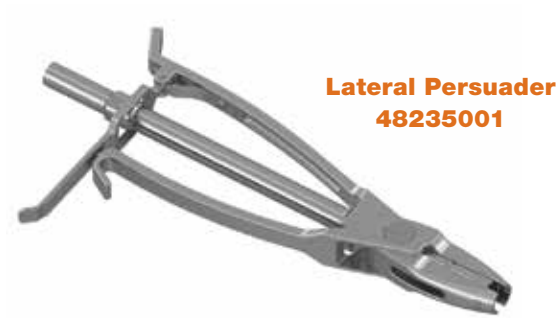

T-Handle (48237097) from the SUK DVR System connected to the proximal end of the tube for added leverage.

Rod Linkage

Option 6: Reduction Clip

The **Reduction Clip** was designed to be a low profile reduction instrument. The low profile of the Reduction Clip allows multiple clips to be used on adjacent segments.

To reduce the rod, attach the inner sleeve of the Reduction Clip to the notches on the tulip head of the screw.

Rotate the outer sleeve clockwise until the rod is fully seated in the tulip head.

If additional torque is needed to persuade the rod, a T-Handle (48237097) from the SUK DVR System can be connected to the proximal end of the tube for additional leverage.

NOTE: Blockers can be inserted through the Reduction Clip into the screw heads.

NOTE: The Xia 3 Universal Tightener is not to be used for final tightening.

NOTE: Reduction Clips can also be used with SUK Derotator Clips to perform direct vertebral rotation.



**Reduction Clip
48237079**



The Reduction Clip was designed to add an additional 2mm of persuasion on the rod while seating it in the tulip head.



Rod Linkage

Option 7: SUK Reduction Tube

The **SUK Reduction Tube** was designed to function as both a reduction instrument and an instrument that can be used for direct vertebral rotation.

Attach the inner sleeve of the SUK Reduction Tube to the notches on the tulip head of the screw.

Rotate the outer sleeve clockwise until the rod is fully seated in the tulip head.

If additional torque is needed to persuade the rod, a T-Handle (48237097) from the SUK DVR System can be connected to the proximal end of the tube for additional leverage.

Once the outer sleeve has been fully threaded down and a secure connection ensured, the SUK Reduction Tube can now be used in direct vertebral rotation maneuvers.

NOTE: Blockers can be inserted through the SUK Reduction Tube into the screw heads. The Short Universal Tightener will not work with the SUK Reduction Tube.

NOTE: The Xia 3 Universal Tightener is not to be used for final tightening.



**SUK Reduction Tube
48237078**



Rod Linkage

Xia 3 SUK Tubes Disassembly Instructions for Cleaning

STEP 1: Unthread the outside tube (1) from the inside tube (2).

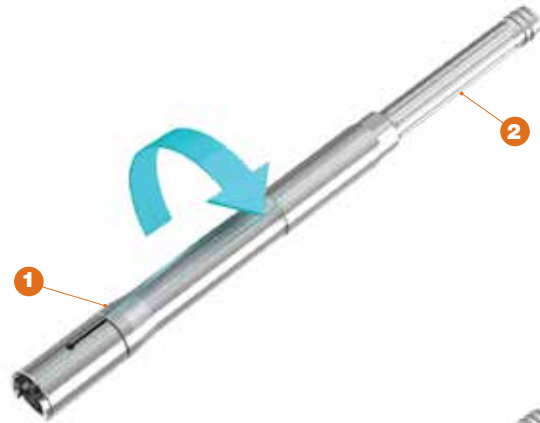

STEP 1

STEP 2: Once the first level of threads is cleared, slide the outside sleeve (1) back until it reaches the stop threads (3).



STEP 2

STEP 3: Unthread the outside sleeve (1) until the stop threads (3) are cleared and continue to pull the outside sleeve off of the inside tube (2).

STEP 3

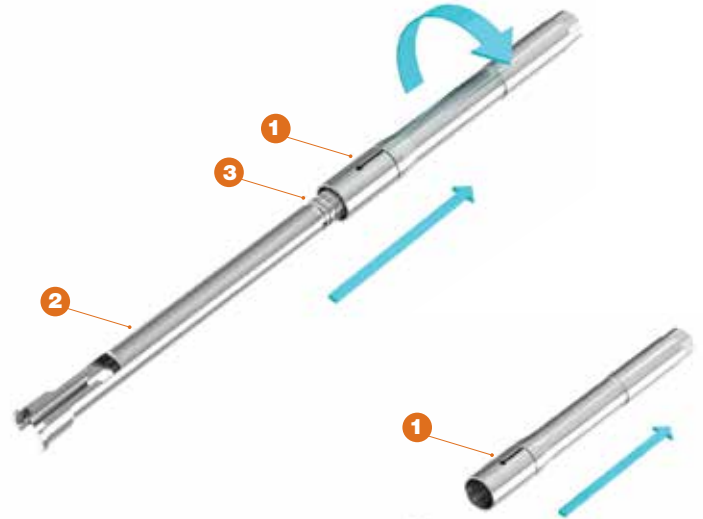

STEP 4: Further separate the outside sleeve (1) from the inside tube (2).

STEP 4



Rod Linkage

To Compress or Distract:

Spinal deformities can be further affected by creating a distraction on the concavity of the deformity and compression on the convexity of the deformity. The compression or distraction maneuvers should be performed once all of the blockers are inserted but not final tightened.



Small Compressor 48236100
Large Compressor 48236101

To accommodate a range of correction needs, small and large **Compressors** and **Distractors** are available.



Small Distractor 48236000
Large Distractor 48236001

Dual axis pivot points evenly distribute compression and distraction loads

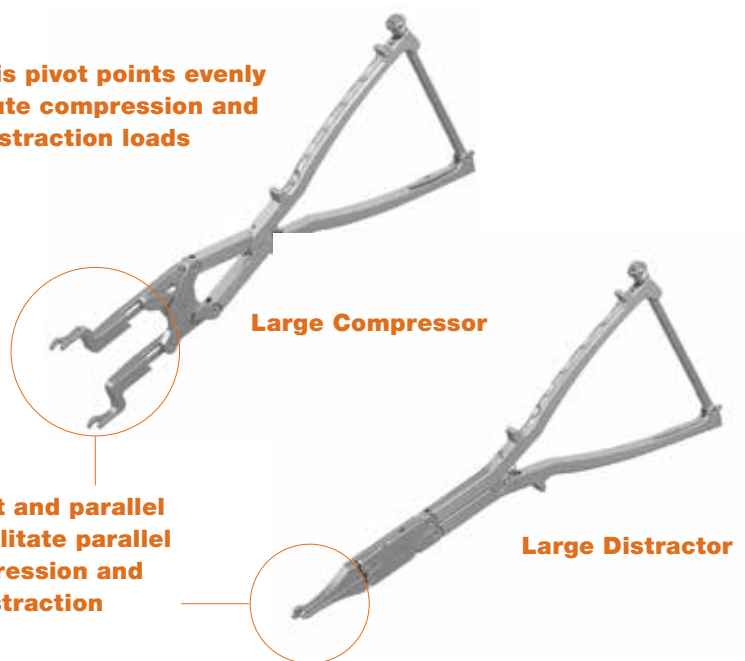

Large Compressor

Straight and parallel tips facilitate parallel compression and distraction

Large Distractor

Final Tightening



Anti-Torque Key
48237026

Short Anti-Torque Key
482397026

Once the correction procedures have been carried out and the spine is fixed in a satisfactory position, the final tightening of the blockers is performed. Use the **Anti-Torque Key** and the **Torque Wrench**. The Anti-Torque Key and Torque Wrench come in two sizes; standard and short.

Place the Anti-Torque Key around the screw head. Place the Torque Wrench through the Anti-Torque Key until it is guided into the blocker.

The Torque Wrench indicates the optimal torque force that must be applied to the implant for final tightening. Line up the two arrows to achieve the final tightening torque of 12Nm.



Xia 3 Torque Wrench
48237028

Short Torque Wrench
482397028



ES2 Torque Wrench
48280081

NOTE: Do not exceed 12Nm during final tightening.

NOTE: The Short Torque Wrench will not fit through the standard Anti-Torque Key.

NOTE: The ES2 Torque Wrench or the MANTIS Redux Torque Wrench may also be used as an alternative to the Xia 3 Torque Wrench to final tighten the Xia 3 blockers.

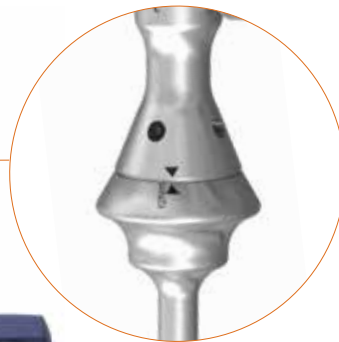

ES2 Counter Torque Tube
48280080

The Anti-Torque Key must be used for final tightening. The Anti-Torque Key performs two key functions:

- Allows the Torque Wrench to align with the tightening axis.
- Helps to maximize the torque needed to lock the implant assembly.

NOTE: The ES2 Counter Torque Tube may also be used in conjunction with the Xia 3 Torque Wrench.

Cross Connectors

Cross Connectors are recommended for increased rotational stability of the construct.

Once the final tightening of the construct is complete, choose the appropriate cross connector size by using the **Cross Connector Measuring Device** or the **MAC Caliper**.



Cross Connector Measuring Device
48230123



MAC Caliper
675024



Monoblock Cross Connector



Multi-Axial Cross Connector

To allow for smooth and rapid insertion of the cross connector over the rods, ensure the spring tightened center nut is loose. This facilitates full range of motion and helps ensure the set screws are adequately backed out.

Use the **Cross Connector Inserter** to place the appropriate length connector on the rod. Use the **3.5mm Hex Driver** or the **Double-Ended 3.5mm Set Screw Inserter** to tighten one of the set screws onto the rod.



Cross Connector Inserter
48230120



3.5mm Hex Driver
48230121



Double-Ended 3.5mm Set Screw Inserter
48237092

Continue with the insertion of the cross connector by fully tightening the second set screw. Return to the first set screw for further tightening.

Confirm that the cross connector is correctly connected to the rods.

For final tightening, the 3.5mm Hex Driver must be used to tighten the set screws, and the **8mm Hex Driver** must be used to final tighten the center nut.



8mm Hex Driver
48230122

Uniplanar Screws



The Xia 3 Uniplanar Screws are designed to provide polyaxial freedom in the cephalad/caudal plane, but remain fixed in the medial/lateral plane. The polyaxial movement in the cephalad/caudal plane facilitates easier rod seating. Prohibiting movement in the medial/lateral plane facilitates direct vertebral rotation, which ultimately helps achieve three dimensional correction of the spine.

Uniplanar screws are visibly distinguishable from standard Xia screws by the non-anodized bone screw as well as two machined grooves on the tulip. They are available in the following sizes:

Xia 3 Titanium Uniplanar Screws:

Diameter	4.5mm	5.0mm	5.5mm	6.0mm	6.5mm	7.0mm	7.5mm
Length	20mm-45mm	20mm-45mm	20mm-55mm	25mm-60mm	25mm-60mm	30mm-60mm	30mm-60mm

NOTE: The machined grooves will be visible on the tulips of the standard Uniplanar screws.

To insert the Uniplanar screws, follow the same screw insertion procedure thoroughly detailed in this surgical technique for the Monoaxial and Polyaxial screws.

NOTE: Uniplanar screws are compatible with all standard Xia 3 Instrumentation.

The **SUK DVR System** can be used in conjunction with Uniplanar screws for vertebral body derotation maneuvers.

The SUK DVR System can be arranged either unilaterally or bilaterally to correct the curvature of the spine by application of cantilever forces applied to the SUK tubes and clamps.

The T-Handle can be used in conjunction with the two-piece tubes to aid in tightening of the outer sleeve providing more rigid fixation between the tube and the Xia 3 Uniplanar screw tulip head.

NOTE: During DVR maneuvers, it is recommended to translate the load evenly over multiple tubes.

NOTE: For more information on direct vertebral rotation maneuvers, see the Xia 3 SUK Direct Vertebral Rotation (DVR) System Surgical Technique.



- SUK Tube - One Piece 48237087**
- SUK Tube - Two Piece 48237077**
- T-Handle, SUK Tube 48237097**
- SUK Derotator Clamp 48237067**
- SUK DVR Reduction Tube 48237078**
- Short SUK DVR Clamp 48237068**
- Long SUK DVR Clamp 48237069**
- Reduction Clip 48237079**

NOTE: Short, medium, and long SUK clamps are compatible with standard one-piece SUK tubes, two-piece SUK tubes, reduction SUK tubes and reduction clips interchangeably.

Reduction Procedures

Xia 3 Reduction Uniplanar Screws can be used during a reduction procedure. The **Xia 3 Reduction Uniplanar Screwdriver** is used to insert the Xia 3 Reduction Uniplanar Screws into the pedicles.

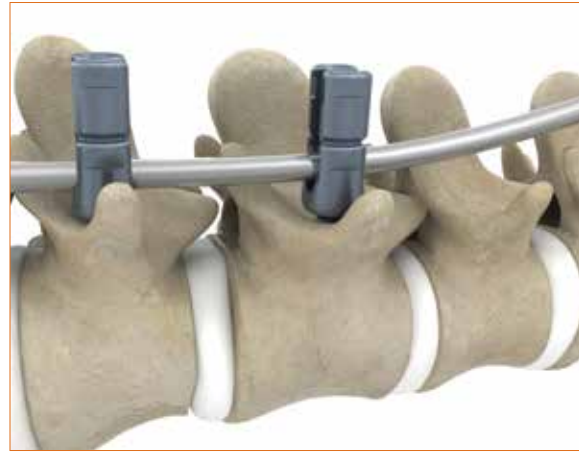

Uniplanar Reduction screws are visibly distinguishable from standard Xia screws by the non-anodized bone screw, the extended tabs of the tulip heads and the two machined grooves on the extended tabs of the tulip head.

The Xia 3 Reduction Uniplanar Screws are available in the following sizes:

Diameter	4.5mm	5.0mm	5.5mm	6.0mm	6.5mm	7.0mm	7.5mm
Length	20mm-45mm	20mm-45mm	20mm-55mm	25mm-60mm	25mm-60mm	30mm-60mm	30mm-60mm

NOTE: The machined grooves will be on the extended tabs of the Reduction Uniplanar screws. Once the tabs are removed from the Reduction Uniplanar screws, the grooves will no longer be present. Use the edge of the break line on the tulip head of the Reduction Uniplanar screws to help distinguish the screws as Reduction Uniplanar screws.

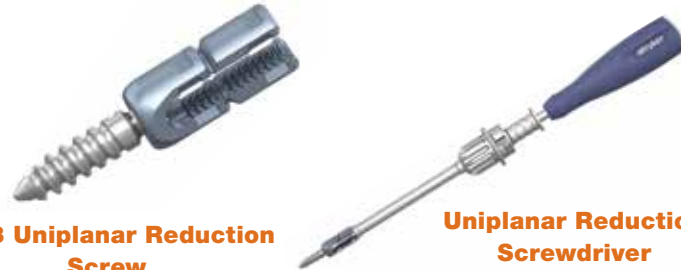

Xia 3 Uniplanar Reduction Screw

Uniplanar Reduction Screwdriver 482331330

Final tightening will take place once the blockers are inserted and the tabs are broken off.

When the Xia 3 Reduction Uniplanar Screws are used, the tabs are broken off when the reduction is complete.

A snap line allows a clean and easy break.

The first tab is broken away using the **Reduction Screw Tab Remover** to grip the tab and bend it in a back and forth motion.

The second tab is broken off in the same manner as the first.

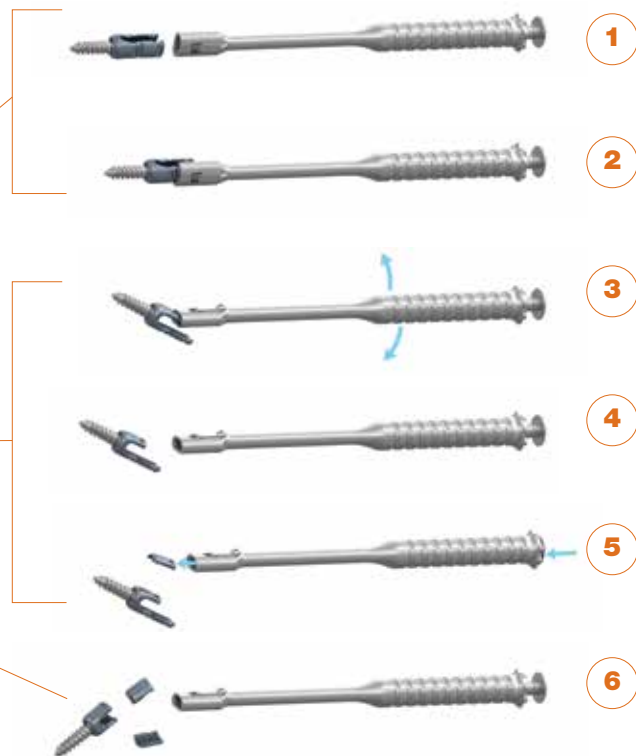

Reduction Screw Tab Remover 482339110

Hooks



The appropriate hook is chosen by a number of factors including patient anatomy, bone quality, correction technique, and the forces applied.

Supralaminar Hooks



Supralaminar Hooks are inserted caudally. A narrow blade hook with a throat size that does not allow pistoning on the lamina is recommended. The ligamentum flavum is dissected from the lamina and a small laminotomy is performed. The **Lamina Preparer** may be used to estimate the appropriate hook size. The blade of the hook sits within the epidural space. The Lamina Preparer also comes in a narrow version to aid in preparing the lamina for hooks with narrow blades.

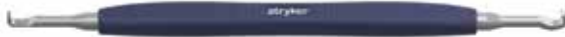

Lamina Preparer
48237021



Lamina Preparer, Narrow
48230110



Standard Hook Holder
48231020



Lateral Hook Holder
48231040

Once the appropriate hook is determined and the site is well prepared, the selected lamina hook is loaded onto the **Hook Holder**. There are three different hook holders available; **Standard Hook Holder**, **Lateral Hook Holder**, **Straight Hook Holder**.



Straight Hook Holder
480231170

Hooks

There are two options for preparing the site and inserting the hook:

Option 1:

A horizontal window is created by excising the ligamentum flavum combined with the limited osteotomy of the edge of the lamina. The window is prepared large enough to accommodate the blade of the hook to be inserted. The blade is then turned 90° and seated on the lamina.

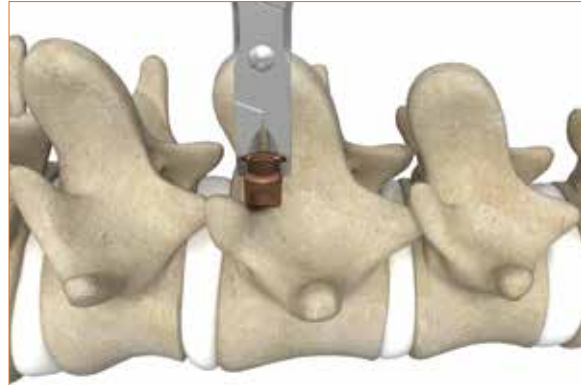

Option 2:

A squared window is created by opening the ligamentum flavum in conjunction with the limited laminotomy. A Lamina Preparer may be used with great care to dissect the ligamentum flavum. The hook is inserted in a downward rotational movement so that the tip of the blade hugs the anterior surface of the lamina at all times.



NOTE: A gentle burring of the lamina is sometimes necessary to ease the access to the canal.

Intralaminar Hooks

Intralaminar Hooks are directed cephalad. The Lamina Preparer is used to dissect the ligamentum flavum from the inferior lamina and prepare a path for the hook. The blade will seat between the anterior surface of the lamina and the ligamentum flavum and not interdural.

Load the hook onto the Hook Holder and insert into the path created by the Lamina Preparer.

The **Hook Impactor** may be used in conjunction with the Hook Holder to facilitate the hook seating against the inferior lamina.



Hook Impactor
48237029

Hooks



Pedicle Hook Preparer
48237025

Pedicle Hooks

Pedicle Hooks are always directed cephalad and recommended for use in the thoracic spine; levels T10 and above. A limited osteotomy at the base of the facet opens the facet joint and exposes the underlying articular cartilage of the superior facet of the caudal vertebra. The **Pedicle Hook Preparer** is inserted into the facet joint with great care, aiming slightly lateral of the midline to identify the pedicle. Once the pedicle is localized, the bifid of the Pedicle Hook Preparer can be utilized to help ensure the forked blade is well applied to the pedicle.























Once the pedicle hook site is clearly identified, the pedicle hook is inserted.

Using the Hook Holder to grip the hook, insert the Hook Impactor into the hook. Slide the hook into the desired position and then gently tamp against the pedicle. Move the hook side to side to ensure the hook is around the pedicle.

As an option, temporarily secure the hook to the Hook Impactor by tightening a blocker. The blocker may be removed once the hook has been placed.

NOTE: To facilitate the introduction of the Pedicle Hook it may be necessary to remove the prominence of the caudal lamina below the hook.

Implants

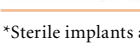
	Reference Number	Sterile* Reference Number	Description
	48230000	48230000S	Blocker
	4823040(20)-(45)	4823040(20)-(45)S	Xia 3 Ø4.0 x 20-45mm Monoaxial Screw
	4823045(20)-(45)	4823045(20)-(45)S	Xia 3 Ø4.5 x 20-45mm Monoaxial Screw
	4823050(20)-(50)	N/A	Xia 3 Ø5.0 x 20-50mm Monoaxial Screw
	4823055(25)-(55)	4823055(25)-(55)S	Xia 3 Ø5.5 x 25-55mm Monoaxial Screw
	4823060(25)-(90)	N/A	Xia 3 Ø6.0 x 25-90mm Monoaxial Screw
	4823065(25)-(90)	4823065(25)-(90)S	Xia 3 Ø6.5 x 25-90mm Monoaxial Screw
	4823070(25)-(90)	N/A	Xia 3 Ø7.0 x 25-90mm Monoaxial Screw
	4823075(25)-(90)	4823075(25)-(90)S	Xia 3 Ø7.5 x 25-90mm Monoaxial Screw
	4823085(25)-(00)	4823085(25)-(00)S	Xia 3 Ø8.5 x 25-100mm Monoaxial Screw
	4823095(40)-(00)	4823095(40)-(00)S	Xia 3 Ø9.5 x 40-100mm Monoaxial Screw
	4823015(40)-(00)	4823015(40)-(00)S	Xia 3 Ø10.5 x 40-100mm Monoaxial Screw
	4823140(20)-(45)	4823140(20)-(45)S	Xia 3 Ø4.0 x 20-45mm Polyaxial Screw
	4823145(20)-(45)	4823145(20)-(45)S	Xia 3 Ø4.5 x 20-45mm Polyaxial Screw
	4823150(20)-(50)	N/A	Xia 3 Ø5.0 x 20-50mm Polyaxial Screw
	4823155(25)-(55)	4823155(25)-(55)S	Xia 3 Ø5.5 x 25-55mm Polyaxial Screw
	4823160(25)-(90)	N/A	Xia 3 Ø6.0x 25-90mm Polyaxial Screw
	4823165(25)-(90)	4823165(25)-(90)S	Xia 3 Ø6.5 x 25-90mm Polyaxial Screw
	4823170(25)-(90)	N/A	Xia 3 Ø7.0 x 25-90mm Polyaxial Screw
	4823175(25)-(90)	4823175(25)-(90)S	Xia 3 Ø7.5 x 25-90mm Polyaxial Screw
	4823185(25)-(00)	4823185(25)-(00)S	Xia 3 Ø8.5 x 25-100mm Polyaxial Screw
	4823195(40)-(00)	4823195(40)-(00)S	Xia 3 Ø9.5 x 40-100mm Polyaxial Screw
	4823115(40)-(00)	4823115(40)-(00)S	Xia 3 Ø10.5 x 40-100mm Polyaxial Screw

*Sterile implants are only available in certain markets outside the U.S. Please contact your Stryker Sales Representative for more information.

Implants

	Reference Number	Sterile* Reference Number	Description
	482334(20)-(45)	482334(20)-(45)S	Xia 3 Ø4.5 x 20-45mm Uniplanar Screw
	4823350(20)-(45)	4823350(20)-(45)S	Xia 3 Ø5.0 x 20-45mm Uniplanar Screw
	482335(20)-(55)	482335(20)-(55)S	Xia 3 Ø5.5 x 20-55mm Uniplanar Screw
	4823360(25)-(60)	N/A	Xia 3 Ø6.0 x 25-60mm Uniplanar Screw
	482336(25)-(60)	482336(25)-(60)S	Xia 3 Ø6.5 x 25-60mm Uniplanar Screw
	4823370(30)-(60)	N/A	Xia 3 Ø7.0 x 30-60mm Uniplanar Screw
	482337(30)-(60)	482337(30)-(60)S	Xia 3 Ø7.5 x 30-60mm Uniplanar Screw
	4823645(20)-(45)	4823645(20)-(45)S	Xia 3 Ø4.5 x 20-45mm Reduction Uniplanar Screw
	4823650(20)-(45)	4823650(20)-(45)S	Xia 3 Ø5.0 x 20-45mm Reduction Uniplanar Screw
	4823655(20)-(55)	4823655(20)-(55)S	Xia 3 Ø5.5 x 20-55mm Reduction Uniplanar Screw
	4823660(25)-(60)	N/A	Xia 3 Ø6.0 x 25-60mm Reduction Uniplanar Screw
	4823665(25)-(60)	4823665(25)-(60)S	Xia 3 Ø6.5 x 25-60mm Reduction Uniplanar Screw
	4823670(30)-(60)	N/A	Xia 3 Ø7.0 x 30-60mm Reduction Uniplanar Screw
	4823675(30)-(60)	4823675(30)-(60)S	Xia 3 Ø7.5 x 30-60mm Reduction Uniplanar Screw
	48230250	N/A	Xia 3 Medium Laminar Hook Standard Blade
	48230201	N/A	Xia 3 Medium Laminar Hook Narrow Blade
	48230202	N/A	Xia 3 Large Laminar Hook Standard Blade
	48230203	N/A	Xia 3 Large Laminar Hook Narrow Blade
	48230204	N/A	Xia 3 Laminar Hook Extended Body
	48230205	N/A	Xia 3 Small Laminar Hook Extended Body
	48230206	N/A	Xia 3 Laminar Hook Offset, Right
	48230207	N/A	Xia 3 Laminar Hook Offset, Left
	48230208	N/A	Xia 3 Large Laminar Hook Angled Blade



















*Sterile implants are only available in certain markets outside the U.S. Please contact your Stryker Sales Representative for more information.

Implants

	Part Number	Sterile* Reference Number	Description
	48230209	N/A	Xia 3 Small Laminar Hook Angled Blade
	48230210	N/A	Xia 3 Thoracic Laminar Hook Standard Blade
	48230211	N/A	Xia 3 Thoracic Laminar Hook Narrow Blade
	48230212	N/A	Xia 3 Thoracic Laminar Hook Small Offset, Right
	48230213	N/A	Xia 3 Thoracic Laminar Hook Small Offset, Left
	48230214	N/A	Xia 3 Thoracic Laminar Hook Large Offset, Right
	48230215	N/A	Xia 3 Thoracic Laminar Hook Large Offset, Left
	48230216	N/A	Xia 3 Small Thoracic Laminar Hook Narrow Blade
	48230217	N/A	Xia 3 Large Offset Hook, Right
	48230218	N/A	Xia 3 Large Offset Hook, Left
	482302(20)-(22)	N/A	Xia 3 Pedicle Hook; Small, Medium, Large
	48230232	N/A	Xia 3 Transverse Process Hook, Right
	48230233	N/A	Xia 3 Transverse Process Hook, Left
	48230240	N/A	Xia 3 Small Laminar Hook Narrow Blade
	48230241	N/A	Xia 3 Small Laminar Hook Standard Blade
	48230260	N/A	Left Sacral Hook
	48230260R	N/A	Right Sacral Hook
	48232(030)-(150)	48232(030)-(150)S	Xia 3 Ø6.0 x 30-150mm CP Ti Rod
	48232480	48232480S	Xia 3 Ø6.0 x 480mm CP Ti Rod
	48232600	N/A	Xia 3 Ø6.0 x 600mm CP Ti Rod
	48233(030)-(150)	48233(030)-(150)S	Xia 3 Ø6.0 x 30-150mm Ti Alloy Rod
	48233480	N/A	Xia 3 Ø6.0 x 480mm Ti Alloy Rod
	48233600	N/A	Xia 3 Ø6.0 x 600mm Ti Alloy Rod
	03822601	N/A	Xia II Ø6.0 x 600mm Vitallium Rod
	48232601	N/A	Xia 3 Ø6.0 x 600mm Vitallium Rod, with hex

*Sterile implants are only available in certain markets outside the U.S. Please contact your Stryker Sales Representative for more information.

Implants

	Part Number	Sterile* Reference Number	Description
	48238(030)-(120)	48238(030)-(120)S	Xia 3 Ø6.0 x 30-120mm Ti Alloy Rad Rod
	48239(050)-(120)	48239(050)-(120)S	Xia 3 Ø6.0 x 50-120mm Ti Alloy Max Rad Rod
	48235(030)-(045)	N/A	Xia 3 Ø6.0 x 30-45mm Vitallium Rad Rod
	48235(050)-(120)	N/A	Xia 3 Ø6.0 x 50-120mm Vitallium Rad Rod with hex
	48235240	N/A	Xia 3 Ø6.0 x 240mm Vitallium Straight Rod with hex
	48235480	N/A	Xia 3 Ø6.0 x 480mm Vitallium Straight Rod with hex
	4866130(03)-(20)	N/A	Radius Ø5.5 x 30-120mm Titanium Spinal Rod, without hex
	486613(110)-(600)	N/A	Radius Ø5.5 x 110-600mm Titanium Spinal Rod, with hex
	486613601	N/A	Radius 600mm Vitallium Spinal Rod
	486613602	N/A	Radius Ø5.5 x 600mm Vitallium Spinal Rod, with hex
	486613241	N/A	Radius Ø5.5 x 240mm Vitallium Spinal Rod, without hex
	486613242	N/A	Radius Ø5.5 x 240mm Vitallium Spinal Rod, with hex
	4866150(30)-(20)	N/A	Radius Ø5.5 x 30-120mm Titanium Rad Rod
	4866152(60)-(20)	N/A	Radius Ø5.5 x 80-120mm Titanium Rad Rod, with hex
	4866151(30)-(20)	N/A	Radius Ø5.5 x 30-120mm Vitallium Rad Rod
	4866155(50)-(20)	N/A	Radius Ø5.5 x 50-120mm Titanium Max Rad Rod
	482360(14)-(26)	482360(14)-(26)S	Xia 3 14-26mm Monoblock Cross Connector
	48236028	48236028S	Xia 3 28-31mm Multi Axial Cross Connector
	48236030	48236030S	Xia 3 30-35mm Multi Axial Cross Connector
	48236035	48236035S	Xia 3 35-44mm Multi Axial Cross Connector
	48236043	48236043S	Xia 3 43-54mm Multi Axial Cross Connector
	48236053	48236053S	Xia 3 53-73mm Multi Axial Cross Connector
	48236070	48236070S	Xia 3 70-99mm Multi Axial Cross Connector

















































*Sterile implants are only available in certain markets outside the U.S. Please contact your Stryker Sales Representative for more information.

Implants

















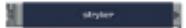





























	Part Number	Sterile* Reference Number	Description
	48235007	48235007S	Xia 3 12mm Parallel Revision Connector Open-Closed
	48235008	48235008S	Xia 3 22mm Parallel Revision Connector Open-Closed
	48235009	48235009S	Xia 3 11mm Closed Parallel RRC
	48235010	48235010S	Xia 3 Angled Loading - Side Loading RRC
	48235011	48235011S	Xia 3 Top Loading - Side Loading RRC
	48235012	48235012S	Xia 3 Axial Revision RRC
	48230133	48230133S	Xia 3 Low Profile Long Closed Offset Connector
	48230138	48230138S	Xia 3 Small Closed Head Offset Connector
	48230139	48230139S	Xia 3 Long Offset Connector Open-Head
	48230141	48230141S	Xia 3 7mm Closed Parallel RRC
	48230143	48230143S	Xia 3 J Hook Offset Connector
	48230144	48230144S	Xia 3 Open Side-Loading Offset Connector

*Sterile implants are only available in certain markets outside the U.S. Please contact your Stryker Sales Representative for more information.

Instruments

	Reference Number	Description		Reference Number	Description
	48237111	Awl		482391320L	Xia 3 Long Monoaxial Screwdriver
	482397002	Sacral Awl		482397004	Xia 3 Low Profile Polyaxial Screwdriver
	48237024	Curved Blunt Probe		482391311S	Xia 3 Short Polyaxial Screwdriver Shaft
	48237055	Thoracic Pedicle Probe		482391311L	Xia 3 Long Polyaxial Screwdriver Shaft
	482397001	Adjustable Curette Probe		482391321S	Xia 3 Short Monoaxial Screwdriver Shaft
	48237060	Pedicle Feeler - Malleable		482391321L	Xia 3 Long Monoaxial Screwdriver Shaft
	48237059	Pedicle Feeler - Medium		482391312S	Xia 3 Short Xia II Polyaxial Screwdriver Shaft
	48237003	Pedicle Feeler - Stiff		482397009	Xia 3 Low Profile Polyaxial Screwdriver Shaft
	48237061	Double Ended Pedicle Feeler		48231326	Iliac Screwdriver - Two Piece
	48230(030)-(105)	Modular Tap, Ø3.0mm-Ø10.5mm		03710620	Xia II Rod Template
	48231201	T-Handle		48238400S	Table-Top Rod Cutter Stand
	48231202	T-Handle, Ratchet		48238400	Table-Top Rod Cutter
	48231301	Round Handle		48237010	French Bender
	48231302	Round Handle, Ratchet		48230191L	Tube Bender Left
	482397006	Small Round Handle		48230191R	Tube Bender Right
	482397005	Small Round Handle, Ratchet		48230140	Rod Insertion Forceps
	48231330	Xia 3 Polyaxial Screwdriver		48231140	Rod Gripper
	48231320	Xia 3 Monoaxial Screwdriver		48237011L	In Situ Rod Bender Left
	48231311	Xia 3 Polyaxial Screwdriver Shaft		48237011R	In Situ Rod Bender Right
	48231321	Xia 3 Monoaxial Screwdriver Shaft		48230180	Coronal Plane Bender Left
	48231330S	Screwdriver Sleeve		48230190	Coronal Plane Bender Right
	482391330S	Xia 3 Short Polyaxial Screwdriver		48230180S	Ball Joint
	482391330L	Xia 3 Long Polyaxial Screwdriver		48237008	Universal Tightener
	482391320S	Xia 3 Short Monoaxial Screwdriver		482397008	Short Universal Tightener

Instruments

	Reference Number	Description		Reference Number	Description
	48237065	Double-Ended Universal Tightener		48237087	SUK Tube - One Piece
	48237109	Inserter Tube		48237077	SUK Tube - Two Piece
	482397109	Short Inserter Tube		48237097	T-Handle, SUK Tube
	48237018	Rod Fork		48237067	SUK Derotator Clamp
	48237016	Persuader		48237078	SUK DVR Reduction Tube
	482397016	Short Persuader		48237068	Short SUK DVR Clamp
	48237015	One Handed Persuader		48237069	Long SUK DVR Clamp
	48236100	Small Compressor		482331330	Xia 3 Reduction Uniplanar Screwdriver
	48236101	Large Compressor		482339110	Reduction Screw Tab Remover
	48236000	Small Distractor		48237021	Lamina Preparer
	48236001	Large Distractor		48230110	Narrow Lamina Hook Preparer
	48237026	Anti-Torque Key*		48231020	Standard Hook Holder
	482397026	Small Anti-Torque Key*		48231040	Lateral Hook Holder
	48237028	Xia 3 Torque Wrench		48231170	Straight Hook Holder
	482397028	Xia 3 Small Torque Wrench		48237029	Hook Impactor
	48280081	ES2 Torque Wrench		48237025	Pedicle Hook Preparer
	48287028	MANTIS Redux Torque Wrench		48230100	Vise Grip
	48280080	ES2 Counter Torque Tube		48237019	Rod Pusher
	48230123	Cross Connector Measuring Device		48237032	Monodriver
	675024	MAC Caliper		482397032	Short Monodriver
	48230120	Cross Connector Inserter		48237091	Modular Monodriver Shaft
	48230121	3.5mm Hex Driver		48237033	Modular Polyadjustment Driver
	48237092	Double-Ended 3.5mm Set Screw Inserter		48231313	Xia 3 Self-Holding Polyaxial Screwdriver Shaft
	48230122	8mm Hex Driver		48237056	Rod Rotation Key (Ø6.0mm)

*Xia 2 Anti-Torque Keys can be used with Xia 3

	Reference Number	Description
	48235001	Lateral Persuader
	48237079	Reduction Clip
	486619160	4.5mm Combination Wrench (Ø5.5mm)
	48237080	Pedicule Marker Inserter
	48237081	Pedicule Markers (Set of 6)
	48237093	Soft Tissue Retractor
	482397007	Jacobs Chuck Handle
	48230001	Degenerative Implant Tray
	48230002	Degenerative Instrument Tray
	48230003	Complex Spine Implant Tray
	48230004	Complex Spine Instrument Tray
	48230005	Complex Spine Hooks and Instrument Tray
	48230006	Complex Spine Rod and Cross Connector Tray
	48230011	Degenerative Implant Tray Version B (SS)
	48230012	Degenerative Instrument Tray Version B (SS)
	48230013	Uniplanar Tray
	48230015	SUK Tray
	48230020	Outlier Implant Tray
	48230010	Outlier Instrument Tray

Xia 3, Xia 4.5, and Xia Growth Rod Conversion Set STRYKER SPINE Spinal Fixation Systems

NON-STERILE AND STERILE PRODUCT

The STRYKER Spine Spinal Fixation Systems are made of devices for fixation of the non-cervical spine. They include smooth rods, screws, hooks, closure screws, connectors, and staples. The components are manufactured from either titanium material (Titanium alloy and CP Titanium), Stainless Steel or Cobalt-Chromium-Molybdenum Alloy.

MATERIALS

Xia 3 Spinal System

Titanium Alloy: Ti6Al4V according to ISO 5832-3 and ASTM F-136: Screws, hooks, closure screws, connectors and rods.
Pure Titanium: CP Ti grade 4 according to ISO 5832-2 and ASTM F-67: Rods
Cobalt-Chromium-Molybdenum Alloy #1 according to ISO 5832-12 and ASTM F-1537: Rods.

Xia 4.5 Spinal System

Titanium Alloy: Ti6Al4V according to ISO 5832-3 and ASTM F-136: Screws, hooks, closure screws, connectors, rods, and staples.
Cobalt-Chromium-Molybdenum Alloy #1 according to ISO 5832-12 and ASTM F-1537: Rods.

Xia Growth Rod Conversion Set

Titanium Alloy: Ti6Al4V according to ISO 5832-3 and ASTM F-136: Growth Rod Connectors

Titanium and Stainless steel implants should not be mixed in a patient; otherwise corrosion may occur resulting in decreased mechanical resistance.

Cobalt-Chromium-Molybdenum Alloy and Stainless steel implants should not be mixed in a patient; otherwise corrosion may occur resulting in decreased mechanical resistance.

MATERIALS IDENTIFICATION

Titanium: symbol **T**

Stainless Steel: symbol **S**

Cobalt-Chromium-Molybdenum: symbol **C**

INDICATIONS

Xia 3 Spinal System

The Xia 3 Spinal System is intended for use in the non-cervical spine. When used as an anterior/anterolateral and posterior, non-cervical pedicle and non-pedicle fixation system, the Xia 3 Spinal System is intended to provide additional support during fusion using autograft or allograft in skeletally mature patients in the treatment of the following acute and chronic instabilities or deformities:

- Degenerative Disc Disease (as defined by back pain of discogenic origin with degeneration of the disc confirmed by patient history and radiographic studies)
- Spondylolisthesis

- Trauma (i.e. fracture of dislocation)
- Spinal stenosis
- Curvatures (i.e., scoliosis, kyphosis, and/or lordosis)
- Tumor
- Pseudarthrosis
- Failed previous fusion

The 5.5 mm rods from the Stryker Spine Radius Spinal System and 6.0 mm Vitallium rods from the Xia Spinal System are intended to be used with the other components of the Xia 3 Spinal System.

When used for posterior, non-cervical, pedicle screw fixation in pediatric patients, the Xia 3 Spinal System implants are indicated as an adjunct to fusion to treat progressive spinal deformities (i.e., scoliosis, kyphosis, or lordosis) including idiopathic scoliosis, neuromuscular scoliosis, and congenital scoliosis. Additionally, the Xia 3 Spinal System is intended to treat pediatric patients diagnosed with: spondylolisthesis/spondylolysis, fracture caused by tumor and/or trauma, pseudarthrosis, and/or failed previous fusion. This system is intended to be used with autograft and/or allograft. Pediatric pedicle screw fixation is limited to a posterior approach.

Xia 4.5 Spinal System

The Xia 4.5 Spinal System is intended for anterior/anterolateral and posterior, non-cervical pedicle and non-pedicle fixation for the following indications:

- Degenerative Disc Disease (as defined by back pain of discogenic origin with degeneration of the disc confirmed by patient history and radiographic studies)
- Spondylolisthesis
- Trauma (i.e. fracture of dislocation)
- Spinal stenosis
- Curvatures (i.e., scoliosis, kyphosis, and/or lordosis)
- Tumor
- Pseudarthrosis
- Failed previous fusion

The Stryker Spine DIAPASON Spinal System, Opus Spinal System, and Xia 4.5 Spinal System can be linked to the Xia 4.5 Spinal System via the rod-to-rod connector when used for the aforementioned indications in skeletally mature patients as an adjunct to fusion.

Except for the staples, when used for posterior non-cervical pedicle screw fixation in pediatric patients, the Xia 4.5 Spinal System implants are indicated as an adjunct to fusion to treat progressive spinal deformities (i.e., scoliosis, kyphosis, or lordosis) including idiopathic scoliosis, neuromuscular scoliosis, and congenital scoliosis. Additionally, the Xia 4.5 Spinal System is intended to treat pediatric patients diagnosed with: spondylolisthesis/

spondylolysis, fracture caused by tumor and/or trauma, pseudarthrosis, and/or failed previous fusion. This system is intended to be used with autograft and/or allograft. Pediatric pedicle screw fixation is limited to a posterior approach.

Xia Growth Rod Conversion Set

The Xia Growth Rod Conversion Set is indicated in patients with potential for additional spinal growth under 10 years of age who require surgical treatment to obtain and maintain correction of severe, progressive, life-threatening, early-onset spinal deformities associated with thoracic insufficiency, including early-onset scoliosis. The Xia Growth Rod Conversion Set may be used with any cleared Xia 4.5 Spinal System rod construct. The Xia Growth Rod Conversion Set is not intended for use in conjunction with staples.

CONTRAINDICATIONS

Contraindications may be relative or absolute. The choice of a particular device must be carefully weighed against the patient's overall evaluation. Circumstances listed below may reduce the chances of a successful outcome:

- Any abnormality present which affects the normal process of bone remodeling including, but not limited to, severe osteoporosis involving the spine, bone absorption, osteopenia, primary or metastatic tumors involving the spine, active infection at the site or certain metabolic disorders affecting osteogenesis.
- Insufficient quality or quantity of bone which would inhibit rigid device fixation.
- Previous history of infection.
- Excessive local inflammation.
- Open wounds.
- Obesity. An overweight or obese patient can produce loads on the spinal system which can lead to failure of the fixation of the device or to failure of the device itself.
- Patients having inadequate tissue coverage of the operative site.
- Pregnancy.
- A condition of senility, mental illness, or substance abuse. These conditions, among others, may cause the patient to ignore certain necessary limitations and precautions in the use of the implant, leading to failure or other complications.
- Foreign body sensitivity. Where material sensitivity is suspected, appropriate tests should be made prior to material selection or implantation.
- Other medical or surgical condition which would preclude the potential benefit of spinal implant surgery, such as the presence of tumors, congenital abnormalities, elevation of sedimentation rate unexplained by other diseases, elevation of white blood cell count (WBC), or marked left shift in the WBC differential count.

ADDITIONAL CONTRAINDICATIONS FOR PEDIATRIC PATIENTS

- Any case where the implant components selected for use would be too large or too small to achieve a successful result.
- Any patient in which implant utilization would interfere with anatomical structures or expected physiological performance.
- Patients having inadequate tissue coverage of the operative site or inadequate bone stock or quality.

These contraindications may be relative or absolute and must be taken into account by the physician when making his decision. The above list is not exhaustive.

GENERAL CONDITIONS OF USE

The implantation of pedicle screw spinal systems must be performed only by experienced spinal surgeons having undergone the necessary specific training in the use of such systems because this is a technically demanding procedure presenting a risk of serious injury to the patient. The information contained in the Package Insert is necessary but not sufficient for the use of these devices. This information is in no sense intended as a substitute for the professional judgment, skill and experience of the surgeon in careful patient selection, preoperative planning and device selection, knowledge of the anatomy and biomechanics of the spine, understanding of the materials and the mechanical characteristics of the implants used, training and skill in spinal surgery and the use of associated instruments for implantation, securing the patient's cooperation in following an appropriately defined post-operative management program and conducting scheduled post-operative follow-up examinations.

INFORMATION FOR PATIENTS

The surgeon must discuss all physical and psychological limitations inherent to the use of these devices with the patient. This includes the rehabilitation regimen, physical therapy, and wearing an appropriate orthosis as prescribed by the physician. Particular discussion should be directed to the issues of premature weight bearing, activity levels, and the necessity for periodic medical follow-up.

The surgeon must warn the patient of the surgical risks and make aware of possible adverse effects. The surgeon must warn the patient that the devices cannot and do not replicate the flexibility, strength, reliability or durability of normal healthy bone, that the implants can break or become damaged as a result of strenuous activity or trauma, and that the devices may need to be replaced in the future. If the patient is involved in an occupation or activity which applies inordinate stress upon the implant (e.g., substantial walking, running, lifting, or muscle strain) the surgeon must advise the patient that resultant forces can cause failure of the devices. Patients who smoke have

been shown to have an increased incidence of non-unions. Surgeons must advise patients of this fact and warn of the potential consequences. For diseased patients with degenerative disease, the progression of degenerative disease may be so advanced at the time of implantation that it may substantially decrease the expected useful life of the appliance. In such cases, orthopaedic devices may be considered only as a delaying technique or to provide temporary relief.

INFECTION

Transient bacteremia can occur in daily life. Dental manipulation, endoscopic examination and other minor surgical procedures have been associated with transient bacteremia. To help prevent infection at the implant site, it is advisable to use antibiotic prophylaxis before and after such procedures..

INSTRUMENTS

Instruments are provided by STRYKER Spine and must be used to assure accurate implantation of the devices. While rare, intraoperative fracture or breakage of instruments can occur. Instruments which have experienced extensive use or extensive force are more susceptible to fracture depending on the operative precaution, number of procedures, disposal attention. Instruments must be examined for wear or damage prior to surgery. Surgeons must verify that the instruments are in good condition and operating order prior to each use during surgery

REUSE

Re-sterilization of implants provided sterile is strictly forbidden, regardless of the method that might be employed.

Never reuse or re-implant spinal surgical implants. These could become contaminated resulting in infection. In addition, even though the device appears undamaged, it may have small defects which could compromise structural integrity reducing its service life and/or leading to patient injury.

HANDLING

Correct handling of the implant is extremely important. The operating surgeon should avoid notching or scratching the device.

ALLERGY AND HYPERSENSITIVITY TO FOREIGN BODIES

When hypersensitivity is suspected or proven, it is recommended that the tolerance of the skin to the materials that make up the implants be checked before they are implanted.

IMPLANT SELECTION AND USE

The choice of proper shape, size and design of the implant for each patient is crucial to the success of the surgery. The surgeon is responsible for this choice which depends on each patient.

Patients who are overweight may be responsible for additional stresses and strains on the device which can speed up metal fatigue and/or lead to deformation or failure of the implants.

The size and shape of the bone structures determine the size, shape and type of the implants. Once implanted, the implants are subjected to stresses and strains. These repeated stresses on the implants should be taken into consideration by the surgeon at the time of the choice of the implant, during implantation as well as in the post-operative follow-up period. Indeed, the stresses and strains on the implants may cause metal fatigue or fracture or deformation of the implants, before the bone graft has become completely consolidated. This may result in further side effects or necessitate the early removal of the osteosynthesis device.

Improper selection, placement, positioning and fixation of these devices may result in unusual stress conditions reducing the service life of the implant. Contouring or bending of rods or plates is recommended only if necessary according to the surgical technique of each system. Rods or plates should only be contoured with the proper contouring instruments. Incorrectly contoured rods/plates, or rods/plates which have been repeatedly or excessively contoured must not be implanted. The surgeon is to be thoroughly familiar with the surgical procedure, instruments and implant characteristics prior to performing surgery. Refer to the STRYKER Spine surgical protocols for additional procedural information. Periodic follow-up is recommended to monitor the position and state of the implants, as well as the condition of the adjoining bone.

METAL COMPONENTS

Some of the alloys utilized to produce orthopaedic implants contain metallic elements that may be carcinogenic in tissue cultures or intact organisms under unique circumstances. Questions have been raised in the scientific literature as to whether or not these alloys themselves may be carcinogenic in implant recipients. Studies conducted to evaluate this issue have not identified conclusive evidence of such phenomena.

SYSTEM COMPATIBILITY

While some degree of corrosion occurs on all implanted metal and alloys, contact of dissimilar metals may accelerate this corrosion process. The presence of corrosion may accelerate fatigue fracture of implants, and the amount of metal compounds released into the body system may also increase. Internal fixation devices, such as rods, hooks, screws, wires, etc., which come into contact with other metal objects, must be made from like or compatible metals. Because different manufacturers employ different materials, varying tolerances and manufacturing specifications, and differing

design parameters, components of the system should not be used in conjunction with components from any other manufacturer's spinal system. Any such use will negate the responsibility of STRYKER Spine for the performance of the resulting mixed component implant.

POSTOPERATIVE CARE

Prior to adequate maturation of the fusion mass, implanted spinal instrumentation may need additional help to accommodate full load bearing. External support may be recommended by the physician from two to four months postoperatively or until x-rays or other procedures confirm adequate maturation of the fusion mass; external immobilization by bracing or casting may be employed. Surgeons must instruct patients regarding appropriate and restricted activities during consolidation and maturation for the fusion mass in order to prevent placing excessive stress on the implants which may lead to fixation or implant failure and accompanying clinical problems. Surgeons must instruct patients to report any unusual changes of the operative site to his/her physician. The physician should closely monitor the patient if a change at the site has been detected.

ADVERSE EFFECTS

- While the expected life of spinal implant components is difficult to estimate, it is finite. These components are made of foreign materials which are placed within the body for the potential fusion of the spine and reduction of pain. However, due to the many biological, mechanical and physicochemical factors which affect these devices but cannot be evaluated in vivo, the components cannot be expected to indefinitely withstand the activity level and loads of normal healthy bone.
- Bending, disassembly or fracture of any or all implant components.
- Fatigue fracture of spinal fixation devices, including screws and rods, has occurred.
- Pain, discomfort, or abnormal sensations due to the presence of the device.
- Pressure on skin from components where inadequate tissue coverage exists over the implant, with the potential extrusion through the skin.
- Dural leak requiring surgical repair.
- Loss of proper spinal curvature, correction, height and/or reduction.
- Delayed Union or Nonunion: Internal fixation appliances are load sharing devices which are used to obtain alignment until normal healing occurs. In the event that healing is delayed, does not occur, or failure to immobilize the delayed/nonunion results, the implant will be subject to excessive and repeated stresses which can eventually cause loosening, bending or fatigue fracture. The degree or success of union, loads produced by weight bearing, and activity levels will, among other conditions, dictate the longevity of the implant. If a nonunion develops or if the implants loosen, bend or break, the device(s) should be revised or removed

immediately before serious injury occurs.

- Loosening of spinal fixation implants can occur. Early mechanical loosening may result from inadequate initial fixation, latent infection, premature loading of the prosthesis, or trauma. Late loosening may result from trauma, infection, biological complications or mechanical problems, with the subsequent possibility of bone erosion, migration and/or pain.
- Peripheral neuropathies, nerve damage, heterotopic bone formation and neurovascular compromise, including paralysis, loss of bowel or bladder function, or foot-drop may occur.
- Serious complications may be associated with any spinal surgery. These complications include, but are not limited to: genitourinary disorders; gastrointestinal disorders; vascular disorders, including thrombus; bronchopulmonary disorders, including emboli; bursitis, hemorrhage, myocardial infarction, infection, paralysis or death.
- Neurological, vascular, or soft tissue damage due directly to the unstable nature of the fracture, or to surgical trauma.
- Inappropriate or improper surgical placement of this device may cause distraction or stress shielding of the graft or fusion mass. This may contribute to failure of an adequate fusion mass to form.
- Decrease in bone density due to stress shielding.
- Intraoperative fissure, fracture, or perforation of the spine can occur due to implantation of the components. Postoperative fracture of bone graft, the intervertebral body, pedicle, and/or sacrum above and/or below the level of surgery can occur due to trauma, the presence of defects, or poor bone stock.

Adverse effects may necessitate reoperation or revision.

The surgeon must warn the patient of these adverse effects as deemed necessary.

ADDITIONAL ADVERSE EFFECTS FOR PEDIATRIC PATIENTS

- Inability to use pedicle screw fixation due to limitations (pedicle dimensions and/or distorted anatomy).
- Pedicle screw malpositioning, with or without neurological or vascular injury.
- Proximal or distal junctional kyphosis.
- Pancreatitis.
- Unintended fusion in Growth Rod patients
- Increased risk of post-operative infection and wound-healing issues in Growth Rod patients
- Increased risk of implant breakage in Growth Rod patients
- Implant prominence (symptomatic or asymptomatic).
- Pressure on the skin from component parts in patients with inadequate tissue coverage over the implant possibly causing skin penetration, irritation, fibrosis, necrosis, or pain.
- Post-operative change in spinal curvature,

loss of correction, height, or reduction.

- Development of respiratory problems (e.g., pulmonary embolism, atelectasis, bronchitis, pneumonia, etc.)

REMOVAL OF IMPLANTS

These implants are temporary internal fixation devices designed to stabilize the operative site during the normal healing process. After healing occurs, these devices serve no functional purpose and can be removed. Removal may also be recommended in other cases, such as:

- Corrosion with a painful reaction
- Migration of the implant, with subsequent pain and/or neurological, articular or soft tissue lesions
- Pain or abnormal sensations due to the presence of the implants
- Infection or inflammatory reactions
- Reduction in bone density due to the different distribution of mechanical and physiological stresses and strains
- Failure or mobilization of the implant

Standard ancillaries provided by STRYKER Spine can be used to remove the implants. Any decision by a physician to remove the internal fixation device must take into consideration such factors as the risk to the patient of the additional surgical procedure as well as the difficulty of removal. Removal of an unloosened spinal screw may require the use of special instruments to disrupt the interface at the implant surface. This technique may require practice in the laboratory before being attempted clinically. Implant removal should be followed by adequate postoperative management to avoid fracture or re-fracture. Removal of the implant after fracture healing is recommended. Metallic implants can loosen, bend, fracture, corrode, migrate, cause pain or stress shield bone.

CAUTION

Stryker Spine has not validated and does not recommend Flash Sterilization. For Product being used in the US, a sterilization wrap that is FDA cleared for the cycle parameters noted is required.

PRE-OPERATIVE PRECAUTIONS

Anyone using STRYKER Spine products can obtain a Surgical Technique brochure by requesting one from a distributor or from STRYKER Spine directly. Those using brochures published more than two years before the surgical intervention are advised to get an updated version.

STRYKER Spine devices can only be used by doctors who are fully familiar with the surgical technique required and who have been trained to this end. The doctor operating must take care not to use the instruments to exert inappropriate stress on the spine or the implants and must scrupulously comply with any operating procedure described in the surgical technique provided by STRYKER Spine. For example, the forces exerted when

repositioning an instrument in-situ must not be excessive as this is likely to cause injury to the patient.

To reduce the risks of breakage, care must be taken not to distort the implants or nick, hit or score them with the instruments unless otherwise specified by the applicable STRYKER Spine Surgical Technique.

Extreme care must be taken when the instruments are used near vital organs, nerves or vessels.

CAUTION

Federal law (U.S.A) restricts this device to sale by or on the order of a licensed physician.

WARNING (U.S.A.)

The safety and effectiveness of pedicle screw spinal systems have been established only for spinal conditions with significant mechanical instability or deformity requiring fusion with instrumentation. These conditions are significant mechanical instability or deformity of the thoracic, lumbar, and sacral spine secondary to spondylolisthesis (grades 3 and 4) of the L5-S1 vertebrae, degenerative spondylolisthesis with objective evidence of neurological impairment, fracture, dislocation, scoliosis, kyphosis, spinal tumor, and failed previous fusion (pseudoarthrosis). The safety and effectiveness of these devices for any other conditions are unknown.

The Xia 3 Spinal System, Xia 4.5 Spinal System, and Xia Growth Rod Conversion Set have not been tested for heating or migration in the MR environment.

ADDITIONAL WARNINGS FOR PEDIATRIC PATIENTS

The safety and effectiveness of the Xia 3 Spinal System has not been established for use as part of a growing rod construct. This device is only intended to be used when definitive fusion is being performed at all instrumented levels.

Growth rod systems should only be used by surgeons who are experienced with pediatric posterior spine surgery procedures and have undergone hands-on training in both device implantation and adjustment. Only surgeons who are familiar with the implant components, instruments, procedure, clinical applications, biomechanics, adverse events, and risks associated with growth rod systems should use this device. A lack of adequate experience and/or training may lead to a higher incidence of adverse events, including neurologic complications.

Growth rod constructs typically require repeated planned-lengthening procedures until a determination is made that the patient is ready for a final fusion procedure. Growth rod patients are more susceptible to post-operative infections and wound-healing issues, as well as the potential for implant breakage requiring unplanned surgical procedures. The physician should discuss these and all other potential complications with the patient and the patient's guardian.

The use of pedicle screw fixation in the pediatric population may present additional risks when patients are of smaller stature or skeletally immature. Pediatric patients may have smaller spinal structures (pedicle diameter and length) that may preclude the use of pedicle screws or increase the risk of pedicle screw malpositioning and neurological or vascular injury. Patients not skeletally mature that undergo spinal fusion procedures may have reduced longitudinal spinal growth, or may be at risk for rotational spinal deformities (the "crankshaft phenomenon") due to continued differential growth of the anterior spine.

Other adverse effects related to pedicle screw fixation, such as screw or rod bending, breakage, or loosening, may also occur in pediatric patients. Pediatric patients may be at increased risk for device related injury because of their small stature.

PRECAUTIONS

The implantation of pedicle screw spinal systems should be performed only by experienced spinal surgeons with specific training in the use of this pedicle screw spinal system because this is a technically demanding procedure presenting a risk of serious injury to the patient.

Based on the fatigue testing results, the physician/surgeon should consider the levels of implantation, patient weight, patient activity level, other patient conditions, etc. which may impact on the performance of the system.

While the final decision on implant removal is up to the surgeon and the patient, in most patients removal is indicated because the implants are not intended to transfer or support forces developed during normal activities. If the device is not removed following completion of its intended use, one or more of the following complications may occur: (1) corrosion, with localized tissue reaction or pain; (2) migration of implant position possibly resulting in injury; (3) risk of additional injury from postoperative trauma; (4) bending,

loosening, and breaking which could make removal impractical or difficult; (5) pain, discomfort, or abnormal sensations due to the presence of the device; (6) possible increased risk of infection; (7) bone loss due to stress shielding; and (8) potential unknown or unexpected long term effects such as carcinogenesis.

ADDITIONAL PRECAUTIONS FOR PEDIATRIC PATIENTS

The implantation of pedicle screw spinal systems in pediatric patients should be performed only by experienced spinal surgeons with specific training in the use of this pedicle screw spinal system in pediatric patients because this is a technically demanding procedure presenting a risk of serious injury to the patient.

Preoperative and operating procedures, including knowledge of surgical techniques, good reduction, and proper selection and placement of the implants are important considerations in the successful utilization of the system in pediatric patients.

The selection of the proper size, shape, and design of the implant for each patient is crucial to the safe use of this device in pediatric patients.

Reconstructive

Hips
Knees
Trauma & Extremities
Foot & Ankle
Joint Preservation
Orthobiologics & Biosurgery

MedSurg

Power Tools & Surgical Accessories
Computer Assisted Surgery
Endoscopic Surgical Solutions
Integrated Communications
Beds, Stretchers & EMS
Reprocessing & Remanufacturing

Neurotechnology & Spine

Craniomaxillofacial
Interventional Spine
Neurosurgical, Spine & ENT
Neurovascular
Spinal Implants



Stryker Spine
2 Pearl Court
Allendale, NJ 07401 USA
t: 201-749-8000
www.stryker.com

A surgeon must always rely on his or her own professional clinical judgment when deciding whether to use a particular product when treating a particular patient. Stryker does not dispense medical advice and recommends that surgeons be trained in the use of any particular product before using it in surgery.

The information presented is intended to demonstrate the breadth of Stryker product offerings. A surgeon must always refer to the package insert, product label and/or instructions for use before using any Stryker product. Products may not be available in all markets because product availability is subject to the regulatory and/or medical practices in individual markets. Please contact your Stryker representative if you have questions about the availability of Stryker products in your area.

Stryker Corporation or its divisions or other corporate affiliated entities own, use or have applied for the following trademarks or service marks: ES2, Mantis, Radius, Stryker, SUK, Vitallium, Xia. All other trademarks are trademarks of their respective owners or holders.